

Turbulence and measuring in boundary layers

without affecting the environment

GRAS Sound & Vibration
Whitepaper // By Dr Rémi Guastavino

Introduction

From our expectations concerning transit times and fuel economy to acceptable levels of comfort, including our perception of what is and is not an acceptable noise level, we have changed a great deal in the past 100, or even 25 years. And while aerodynamics has long been a factor in fuel economy, we are now travelling so fast that aerodynamic noise is the main concern for sound quality in cars, busses, trains and aircraft. In fact, noise is joining efficiency as a primary influence in the aerodynamic design. A badly designed side mirror or wing element, for example, can produce a significant amount of extra noise. These are now perceived as major flaws and unacceptable, as airport noise limits become more stringent and the overall sound quality of the vehicle and speech intelligibility inside the cabin have become key factors in the vehicle design. The advent of new technologies can result in noise that was previously unnoticed, such as in electric vehicles where the masking noise of engine and transmission are no longer present.

The key to making quieter and more fuel-efficient vehicles is to understand turbulence and how to get accurate measurement data. Turbulence is the main source of noise generation when dealing with high-speed flow or large bodies. If the turbulence is already present in the flow, we talk about turbulence interaction noise, but turbulence can also be produced by an object in a different boundary layer and produce high levels of noise when the turbulent flow passes an edge. Even the edges of a measurement device itself can result in interaction noise within the area being measured, and must be minimized for valid data. It is therefore vital to minimize the number and size of any additional edge elements introduced to the measurement environment for the most accurate and realistic data.

With an eye towards acquiring that accurate, valid data for improved data, improved design and improved simulation, this whitepaper will cover the types of aerodynamic flow around a body, the importance of the measurement sensor diaphragm size in acquiring accurate data and the need to minimize the aeroacoustic impact of the sensor in the measurement area. This paper will also address the utility of nondestructive sensor mounting in high-cost structures and areas where drilling for flush-mounting is not possible. Finally, ultra-thin surface microphone and flush-mounted microphone data will be compared.

Laminar vs Turbulent Flow

Flow can be divided in two main types: 1) laminar and 2) turbulent.

1. Laminar flow is characterized by fluid particles following smooth paths in parallel layers with no or little disruption between the layers (Figure 1). Laminar flows have a parabolic velocity profile. The velocity of the flow is at its lowest at the walls and highest in the center of the stream.

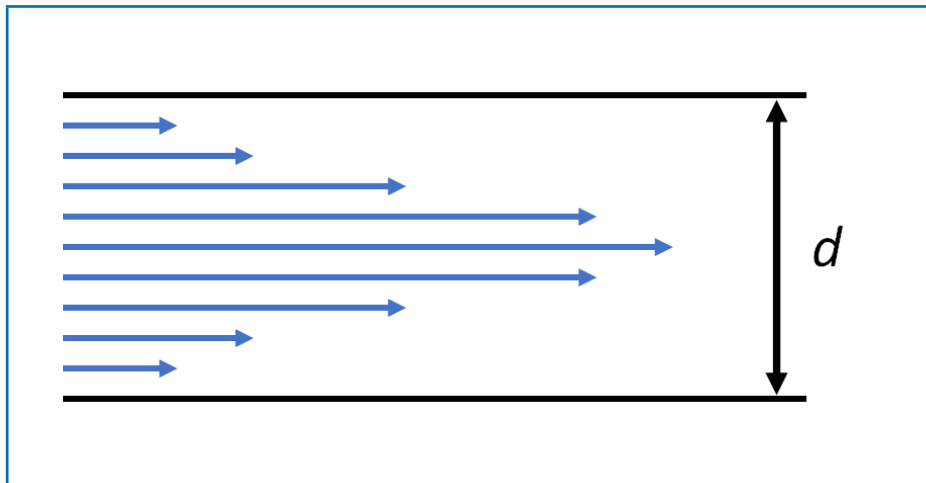

FIGURE 1.

Laminar flow in a closed pipe. The length of the arrows shows the approximate velocity of the fluid flow.

2. Turbulent flow is fluid motion characterized by chaotic changes in pressure and flow velocity (Figure 2).

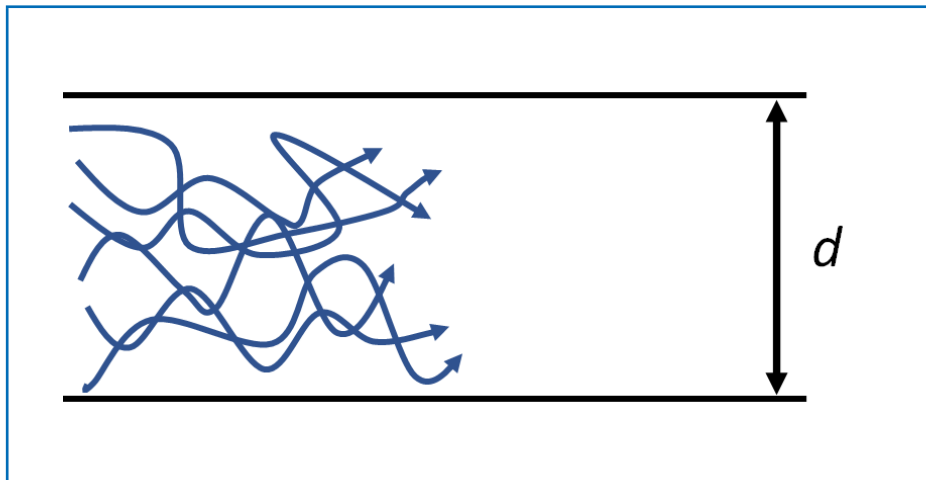

FIGURE 2.

Turbulent flow in a closed pipe.

One of the main focus points of wind noise testing in the aerospace industry is measurement in boundary layers, where there is considerable interest in separating the acoustic signal from flow-induced turbulent or hydrodynamic noise. And special attention is paid to determine the exact location where the flow goes from laminar (relatively quiet) to turbulent and noisy. That location is called the transition region (Figure 3).

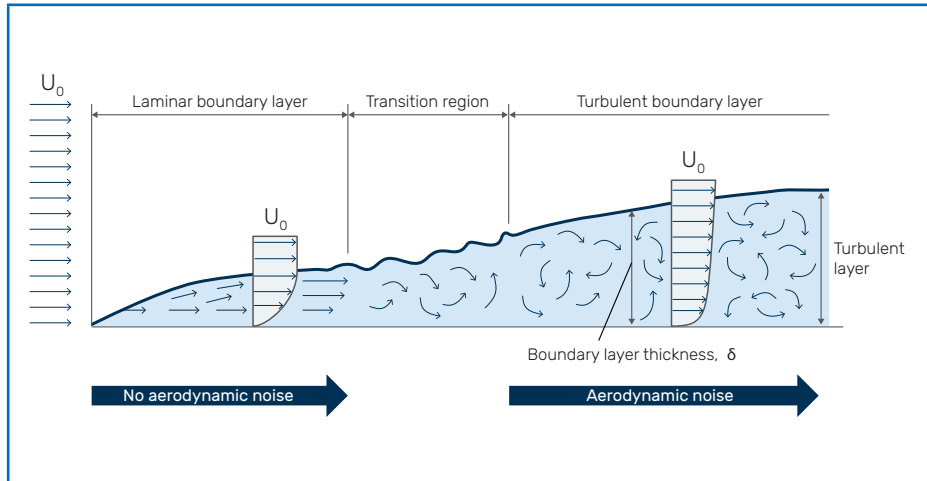

FIGURE 3.

Boundary layers in flow.

The transition region is also very important when dealing with stall in an airfoil (such as the wings of a plane). In aeronautics, stall is the condition where maximum lift is achieved and where, if the angle of attack increases or decreases, lift begins to decrease. When the angle of attack increases, the separated flow region moves forward and affects lift and increases drag. This means that the optimal angle (maximum lift and minimal drag) correlates to the location of the separation region (Figure 4). This optimal angle also ensures minimum fuel consumption and noise production.

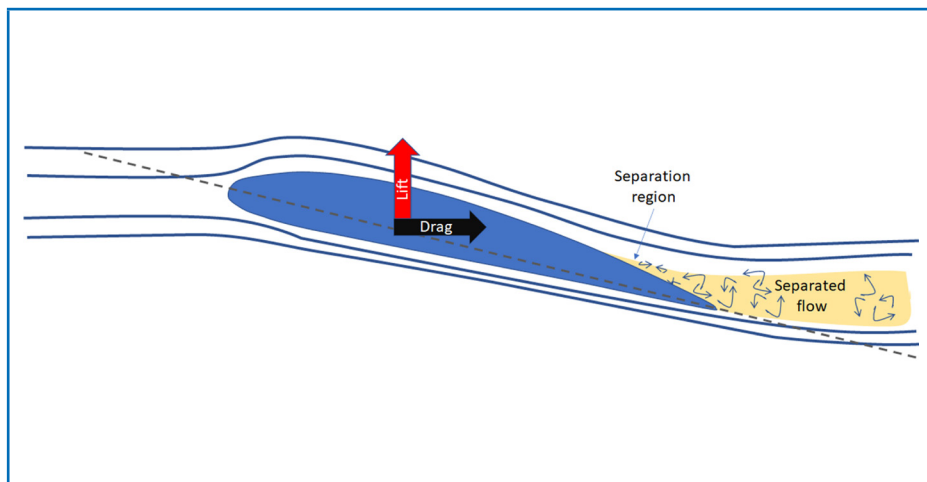

FIGURE 4.

Flow around an airfoil.

Microphones or pressure sensors can be used to monitor the separation region because turbulence has a characteristic acoustic signature and can be differentiated from laminar flow acoustic signatures. The level of the turbulence increases from the separation region to the separated flow, and results in vortical systems forming behind obstacles. These vortices and turbulence travel with a velocity comparable to the flow velocity and are the main sources of hydrodynamic noise. When the speed is high enough, the acoustic component is typically very small in amplitude compared to the hydrodynamic noise.

One of the particularities of hydrodynamic noise is that turbulence propagates with the flow and not with the speed of sound. This results in much shorter wavelengths. In a wind tunnel, turbulence travels in a motion parallel to the microphone diaphragm, so special care must be taken to avoid “microphone size effect” at higher frequencies.

When size matters...

Sensing-element size

Based on their physical size, sensors will have a natural tendency to average sound waves coming from a direction parallel to the surface of their sensing element (or diaphragm). This is a common measurement scenario for microphones that are mounted flush on a smooth wall with a flow passing by at a 90° angle, or grazing flow.

If the size of the wavelength is not significantly larger than the microphone diaphragm, the integration of the applied pressure will have a tendency to under-represent the real sound pressure level. This tendency will continue to the point where the size of the wavelength equals the size of the microphone diaphragm and the integration over the entire surface will experience both positive and negative pressure at the same time and return a net output of zero (Figure 5).

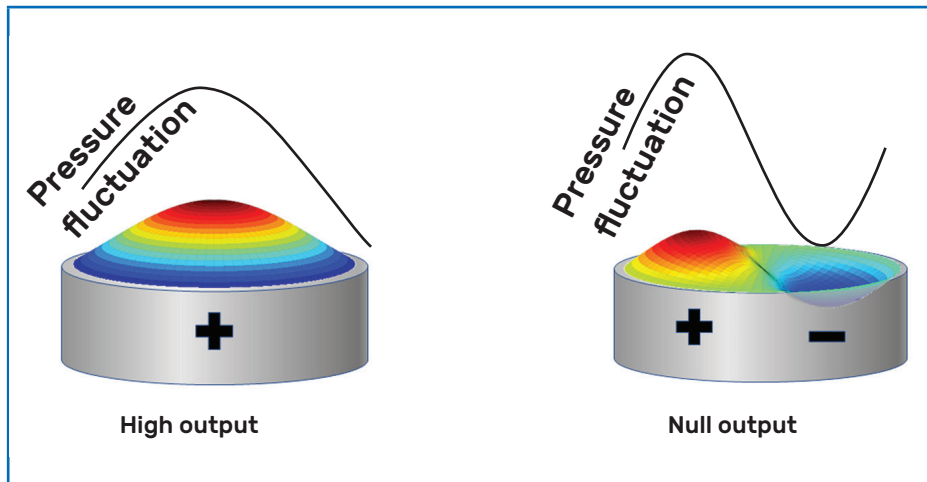

FIGURE 5.
Influence of the
diaphragm size.

In other words, a sensor with a large sensing element will have a tendency to under-represent the high-frequency content sooner than a sensor with a smaller sensing element (Figure 6).

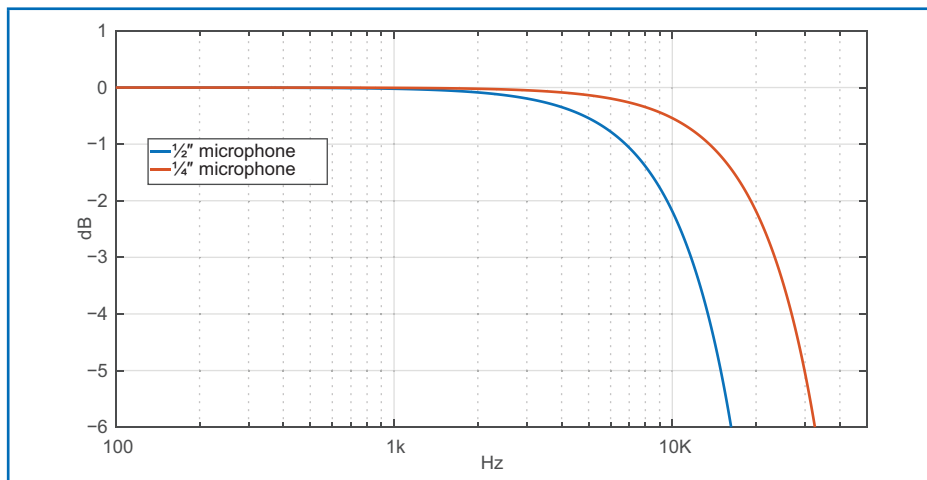
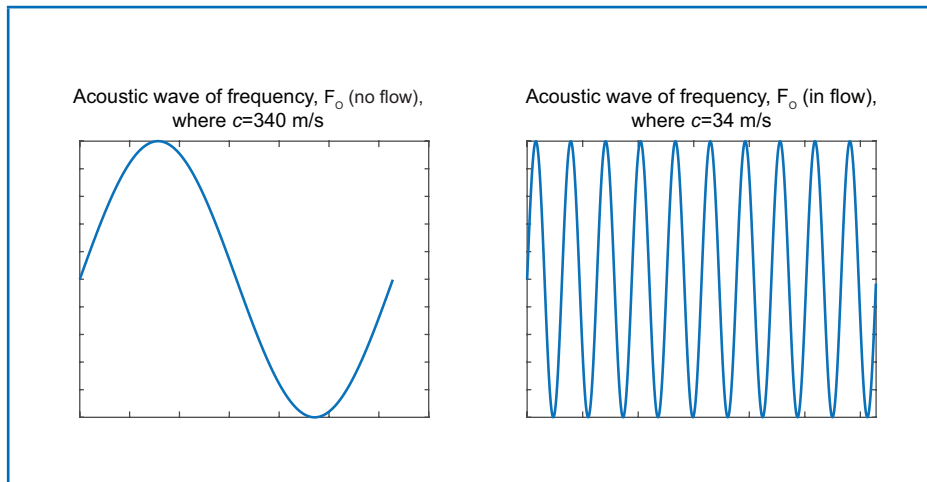

FIGURE 6.
90° incidence responses
based on membrane size.

This effect is even more pronounced when the flow is slow. Aeroacoustics disturbances that travel with the flow will have a much higher wave number, and the cancellation will come much sooner* (Figure 7).

* A wave number is the spatial frequency of a wave and is measured in cycles per unit distance.

**FIGURE 7.**

Wave number going from 1 to 10 at the same frequency but at a different flow speed.

Therefore, a microphone with an optimized active membrane size of slightly less than 1/4", such as the GRAS Type 48LX-1, would result in a minimum averaging effect while keeping a low noise floor and a reasonable output (Figure 8).

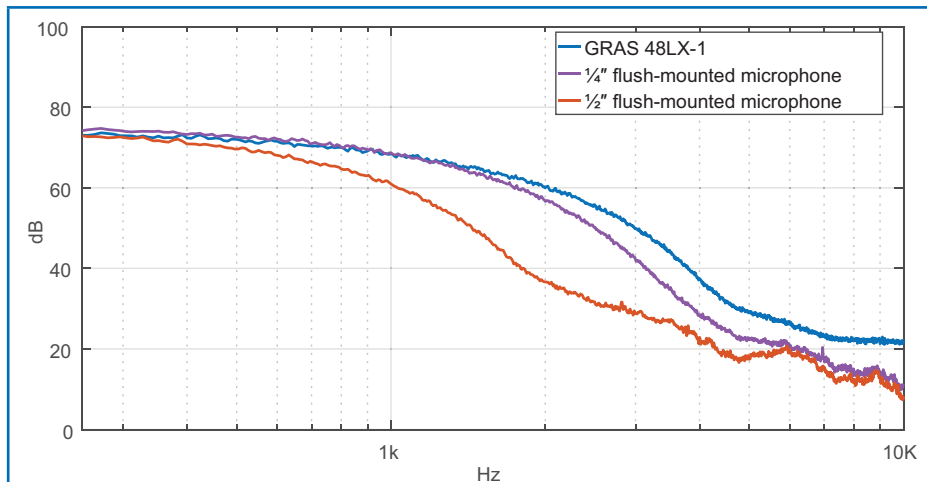
**FIGURE 8.**

High-frequency aero-acoustics noise measurement @15 m/s. The under-representation of the high-frequency content for the 1/2" microphone is due to averaging on the diaphragm.

In the case of in-flow measurement where the characterization of the boundary layer is important, measuring with a sensor having a large sensing size will result in a large under-representation of the turbulent high-frequency content. This under-representation is due to the turbulence traveling at the same speed as the flow and having much higher wave numbers that will be averaged sooner.

Overall sensor size

The physical presence of a microphone will disturb the flow and cause unwanted aeroacoustics and whistling noise. The solution until now has been to flush mount* the microphone into the wall of wind tunnels, or worse, to drill into the device under test (DUT). This is not always possible (in a glass window, for example), and it is always intrusive, expensive and potentially destructive.

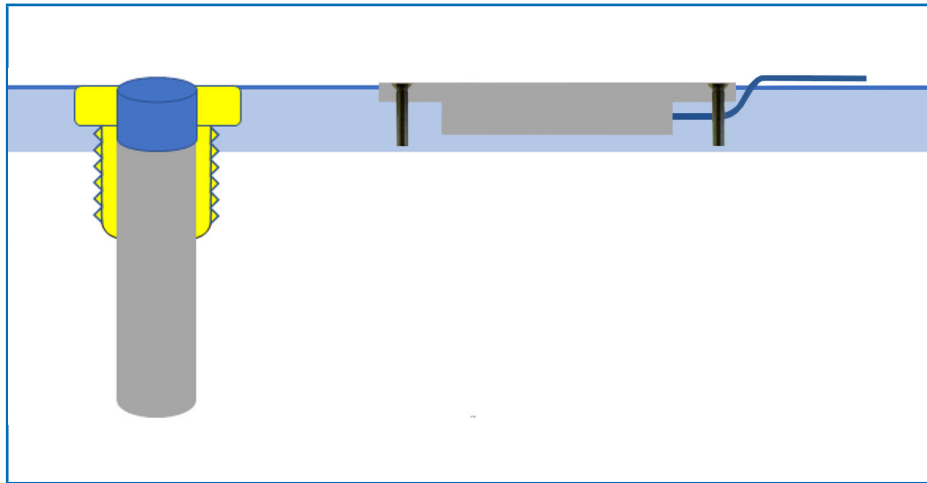
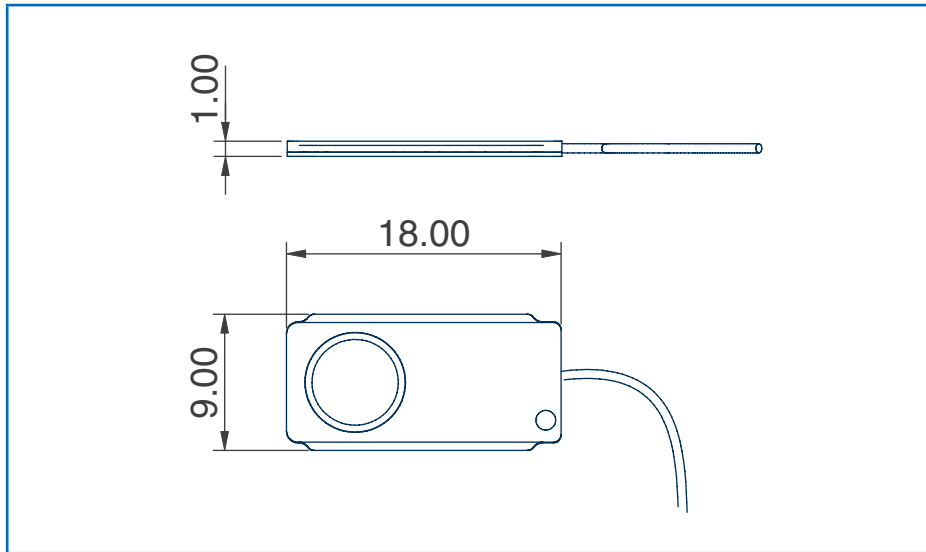

FIGURE 9.

Flush mounting option for regular (left) and surface microphones (right).

Due to the importance of size and the potentially destructive and ruinous effects of drilling into a prototype DUT, thinner and nondestructive methods of mounting microphones on the surface of the DUT, such as GRAS Type 48LX (Figure 10) are desirable. The microphone (with a height of 1 mm and mounting footprint of 9 x 18 mm) is so small that, when correctly mounted in the specially designed fairing, it is almost impossible to distinguish between the frequency response of the 48LX and a traditionally flush-mounted measurement microphone.

* *Flush mounting a microphone entails making small cavities on the surface on the studied object and often adding threading and screws.*

**FIGURE 10.**

48LX-1—dimension in mm.

This means that drilling holes is no longer required. The microphone can be easily and time-efficiently mounted on any planar and curved surfaces as shown in Figure 11 (left).

**FIGURE 11.**

Faring mounting (left; courtesy of Volvo Car Corporation) versus flush mounting (right).

Conclusion

Microphones with extremely low profiles, such as GRAS 48LX-1, allow measurements that are as accurate as flush-mounted microphones without the hassle of making permanent physical damage to the DUT.

The smaller membrane size extends the measurement range (compared to classic microphone designs that under-represent the high-frequency content) without compromising the noise floor, as shown in Figure 12.

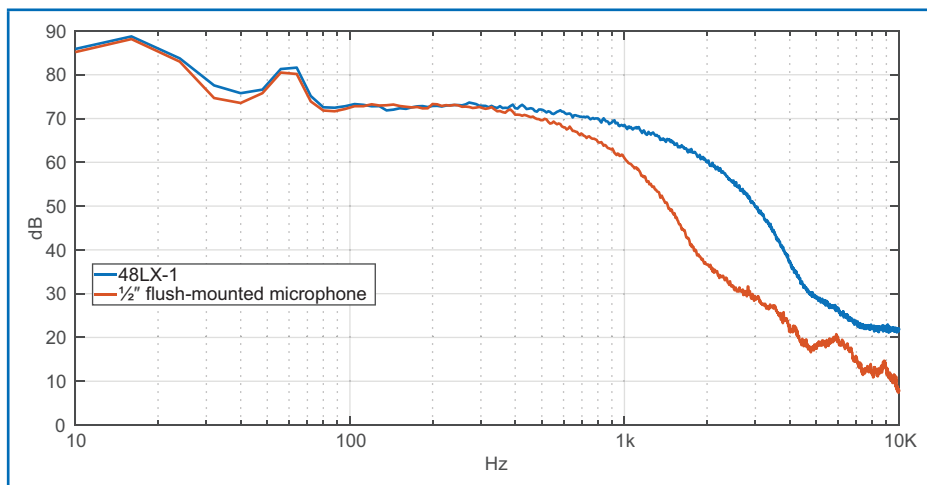

FIGURE 12.

Aeroacoustics noise for 48LX-1 in fairing versus surface microphone flush at 15m/s.

The understanding of turbulence and flow and how they affect the accuracy of measurement data is vital in the acquisition of valid, actionable data in boundary layers. With this understanding it can be seen that the minimization of measurement device edges directly results in reduced interaction noise within the area being measured, and a smaller diaphragm size allows for an extended measurement range. This culminates in improved data, improved design and improved simulation. The added utility of ultra-thin surface microphones provide additional options for non-invasive mounting on expensive DUTs and non-drillable surfaces or scenarios where microphone placement is subject to change.